

## DEVELOPMENT OF ADVANCED PAINTING SYSTEM

Md. Amirul Mominin<sup>1,\*</sup>, Chandan Dev Sharma<sup>2</sup>, Md. Tazul Islam<sup>3</sup> and Syed Masrur ahmmad<sup>4</sup>

<sup>1-4</sup>Student, Department of Mechanical Engineering, CUET, Chittagong-4349, Bangladesh

<sup>1,\*</sup>atikcuet002@gmail.com , <sup>2</sup>chandandevsharma47@gmail.com , <sup>3</sup>tazul2003@yahoo.com , <sup>4</sup>masrur@cuet.ac.bd

**Abstract-** An automatic painting system is designed that can paint an object of various shape such as round, rectangular, hexagonal etc. This painting system consists of three main parts they are Painting arrangement, circular table and robotic hand. Painting arrangement consists of a color spray that can move vertically up and down to paint the whole length of the object. It can move horizontally also. Circular table is the most special part of this painting system. This table can rotate at any required angle during painting. A robotic hand is used to take an object on the circular table. After completing painting robotic hand is used to pass the object. Using this automatic painting system in industry any product of any shape can be painted without any human effort. The whole process can run automatically for hours and hours by switching only one button. A large amount of money will be saved by using this automatic painting system in industries and other commercial purposes.

**Keywords:** Painting-system, robotic-hand.

### 1. INTRODUCTION

The objective is to design an automatic painting system that can paint object of different shapes. It will play an important role in the industries to reduce human effort and to save money and time.

The “Development of an advanced painting system” project entails the development of such a machine which has three main parts. First part is the “painting arrangement” which consists of spray nozzle and can able to move the nozzle vertically. The second part is “circular table” which can rotate at any required angle. The third part is a “robotic hand” which takes the object on the circular table from the storage and push it to the storage after painting.

#### 1.1 Problem Statement

(1) The first sub problem is to establish (produce) a conceptual design and then develop a detailed design of each of the different constituents of the system.

(2) The second sub problem is to develop and build all the components of the machine and finally integrate.

(3) The third sub problem is to test the operation of the built model and assess its performance and limitations.

#### 1.2 Hypothesis

(1) All units, mainly electronics, and mechanical parts will be integrated such that a coherent operation may result.

(3) The final model will be robust and able to execute commands and perform the requested task.

### 2. LITERATURE REVIEW

The desire of making work easy is a part of human nature. Building a system or machine that can reduce human effort is very fascinating. Automatic machines are very popular in this era and industries often use automatic machines to reduce human efforts and to increase production.

#### 2.1 Servo Motor

A servo motor is a rotary or linear actuator that allows for precise linear or angular position, velocity and acceleration. It consists of a suitable motor coupled to a sensor for position feedback. It also requires a sophisticated controller as well as a dedicated module designed for use with servomotors.

#### 2.2 DC Motor

A DC motor is any of a class of electrical machines that converts direct current electrical power into mechanical power. The most common types rely on the forces produced by magnetic fields. Nearly all types of DC motors have some internal mechanism, either electromechanical or electronic to periodically change the direction of current flow in part of the motor. Most types produce rotary motion; a linear motor directly produces force and motion in a straight line. DC motors were the first type widely used, since they could be powered from existing direct-current lighting power distribution systems. A DC motor's speed can be controlled over a wide range, using either a variable supply voltage or by changing the strength of current in its field windings.

### 3. SYSTEM DESIGN AND IMPLEMENTATION

An automatic system is made of a mechanical and an electrical system and also a built in software to control them. Designing such an automatic system requires multidisciplinary involved span from electronics, programming, control engineering, mechanical design, material and manufacturing. The design of this system was done in two main phases. The first one was the conceptual design and the second one was the detailed design.

#### 3.1 Conceptual Design

The mechanical design and the size of the machine was important and it had to be able to move the spray nozzle vertically and rotate the circular table at any required angle. It had to be able to move the robotic hand.

#### 3.2 Detailed Design

Detailed design of an automatic color system is divided in three subsystems: Mechanical structure, Electronics and Programming.

##### 3.2.1 Mechanical Design

The mechanical design consists of design of all the mechanical part of the machine. First we had to design the circular table. Then we designed the color spray arrangement which is able to move the spray nozzle vertically. Then we design the robotic hand.

##### 3.2.2 Electronics

This automatic system being an electromechanical system it has several circuits used in this project. The most important circuit is microcontroller circuit and motor driver circuit.

##### 3.2.2.1 Microcontroller

A microcontroller is a small computer on a single integrated circuit containing a processor core, memory and programmable input/output peripherals microcontroller are used in automatically controlled devices. Here an arduino uno is used which contains an ATmega328P microcontroller. The microcontroller is programmed so that it can execute program and give output according to the input. Microcontroller gives signal to the motor driver circuit.

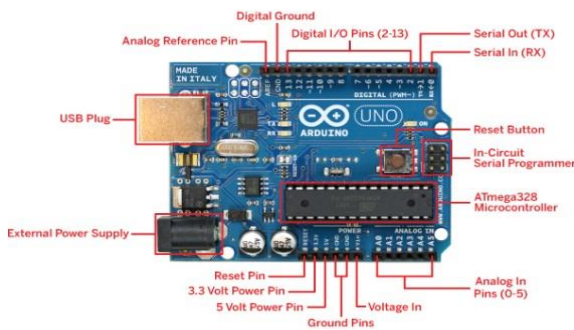

Fig 1: Arduino uno

##### 3.2.2.2 Motor Driver

Motor driver is used to control motor. Motor driver acts as interface between microprocessors and motors. Most

microprocessors operate at low voltage and require a small current to operate where the motors require relatively higher voltage and current. So microprocessor cannot supply sufficient current to the motor. That's why motor driver is used to supply the required voltage and current to the motor. Another vital use of the motor driver is to drive the motor bi directionally.

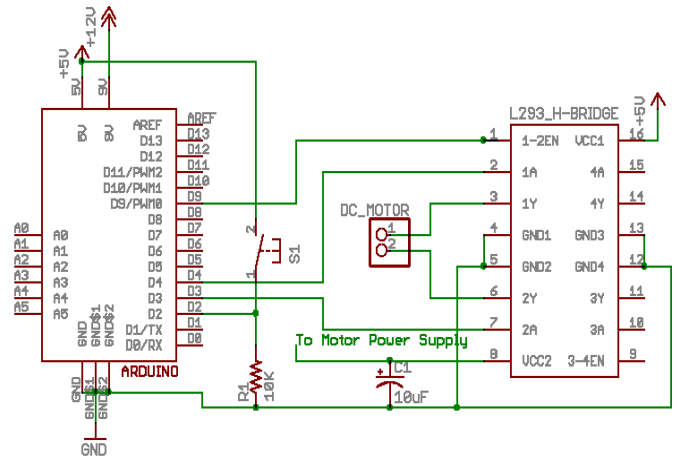

Fig 2: Arduino and Motor driver circuit diagram

### 3.3 Programming and Software

The implementation of an automatic painting system requires some programming. Arduino programming is based on C programming language. The program developed in the arduino board is the main brain of the system. Most of the control is done by the arduino and manages the entire task to be carried out. To complete this project it requires some software used for programming, for simulation, for circuit design and for burn the code to the Arduino.

1. Arduino software
2. Proteus

### 4. WORKING PRINCIPLE

The aim was to paint object of different shapes. To do so the product that is to be painted is supplied to the painting machine by a conveyor belt. There is a sensing unit before the machine. When the object approach the sensor and if sensed by the sensor then the belt stop. Then the robotic hand push the object to the circular table in front of the painting nozzle. The machine starts painting by spraying color through nozzle and the circular table starts rotating with a uniform speed. For painting a circular shaped object the table rotate with uniform speed, for rectangular shaped table moves at an angle of 90 degree 4 times and for hexagonal object table moves at an 60 degree 6 times.

When the painting is completed the nozzle stop spraying and circular table stops rotating. Then the painted product is push to the conveyor belt again to supply the product at the storage.

#### 4.1 Flow Chart

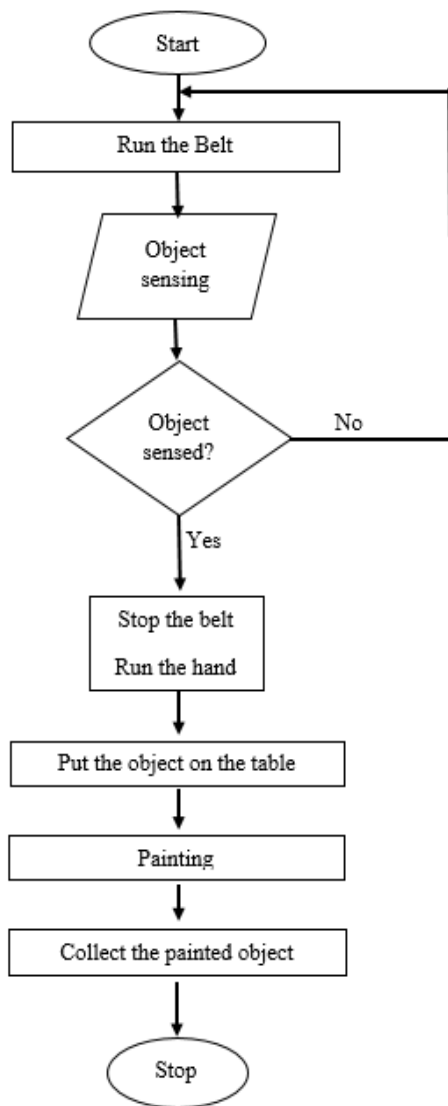

#### 5. TEST AND RESULT

Integration of parts is the most interesting and difficult task of developing a device. It reveals a lot of crucial issues. Integration resulted in a number of process.

##### 5.1 Integration of Mechanical Parts

All the mechanical parts were integrated and joints were made very carefully. Then the motors installed and the moving parts were checked.

##### 5.2 Integration of Electronics

All the electronics as well as circuit board, arduino, sensor and the power cables were installed very carefully and isolated to a safe place.

##### 5.3 Performance

The aim of this project was to develop such an automatic painting system that can paint exterior of object of different shapes like circular, rectangular, hexagonal etc. The performance of this device is satisfactory.

Table 1: Performance Table

Function	Feature	Performance
Spray nozzle motion	Up	√
	Down	√
Rotation of circular table	Clockwise	√
	Anti-clockwise	√
Motion of hand	Forward	√
	Backward	√
Sensor	Object detection	√

#### 6. DISCUSSION

The performance of the developed automatic painting system is quite satisfactory. Further study and development can be implemented to this automatic painting system. They are

1. A video camera and image processing software can be used to sense the color and also sense that whether the object is painted before or not.
2. Image processing software can be used to detect any fault in painting.
3. Multicolor system can be used.
4. Can be upgraded to paint bottom and upper surface also.

#### 7. CONCLUSION

Quality, productivity and safety this is the triad of competitiveness. Though automatic device is much expensive compare to other but it has a great importance in fastest and large production. Automatic technology now delivers all three at lower cost with more flexibility with greater use of implementation. Hence development of automatic machine became popular recently due to fact that industry needs automatic machine to relax human from tedious and dangerous jobs. So the automatic painting system will-

1. Reduce the labor cost.
2. Reduce the cost of painting
3. Reduce the worker's fatigue.

#### 8. REFERENCES

- [1] P.Keerthanaa, K.Jeevitha, V.Navina, G.Indira, S.Jayamani "Automatic wall painting robot", International Journal of Innovative Research in Science, Engineering and Technology, Vol. 2, Issue 7, July 2013.
- [2] F.A.Mahmood, M.N.Amin, M.A.Mominin, M.Shahriar, M.T.Islam "Development of Automatic Wall Painting Robot", 7<sup>th</sup> IMEC & 16<sup>th</sup> Annual Paper Meet, 21-22 November, 2014 Dhaka, Bangladesh.
- [3] Noumee Subayer "Design & Fabrication of automated wall painting machine" Final year project, Chittagong University of Engineering & Technology (CUET).
- [4] Takuya Gokya, Masayuki Takasu, Sumio Fukuda "Development of wall painting robot" Tokyu

Construction Co. Ltd.

- [5] [http://www.scmgroup.com/en/products/finishing-systems.c920/spraying-robots-for-panels.926/valtorta-bravorobot.605\\_](http://www.scmgroup.com/en/products/finishing-systems.c920/spraying-robots-for-panels.926/valtorta-bravorobot.605_)(7 August, 2015).
- [6] <http://hilustrespraypainting.com.au/robotic-spray-painting>. (10 August,2015)